

DATA SHEET

PCF8573

Clock/calendar with Power Fail Detector

Product specification
Supersedes data of May 1989
File under Integrated Circuits, IC12

1997 Mar 28

Clock/calendar with Power Fail Detector**PCF8573**

CONTENTS

| | |
|--------|---|
| | FEATURES |
| 2 | GENERAL DESCRIPTION |
| 3 | QUICK REFERENCE DATA |
| 4 | ORDERING INFORMATION |
| 5 | BLOCK DIAGRAM |
| 6 | PINNING |
| 7 | FUNCTIONAL DESCRIPTION |
| 7.1 | Oscillator |
| 7.2 | Prescaler and time counter |
| 7.3 | Alarm register |
| 7.4 | Comparator |
| 7.5 | Power on/power fail detection |
| 7.6 | Interface level shifters |
| 8 | CHARACTERISTICS OF THE I ² C-BUS |
| 8.1 | Bit transfer |
| 8.2 | Start and stop conditions |
| 8.3 | System configuration |
| 8.4 | Acknowledge |
| 9 | I ² C-BUS PROTOCOL |
| 9.1 | Addressing |
| 9.2 | Clock/calendar READ/WRITE cycles |
| 10 | LIMITING VALUES |
| 11 | HANDLING |
| 12 | DC CHARACTERISTICS |
| 13 | AC CHARACTERISTICS |
| 14 | APPLICATION INFORMATION |
| 15 | PACKAGE OUTLINES |
| 16 | SOLDERING |
| 16.1 | Introduction |
| 16.2 | DIP |
| 16.2.1 | Soldering by dipping or by wave |
| 16.2.2 | Repairing soldered joints |
| 16.3 | SO |
| 16.3.1 | Reflow soldering |
| 16.3.2 | Wave soldering |
| 16.3.3 | Repairing soldered joints |
| 17 | DEFINITIONS |
| 18 | LIFE SUPPORT APPLICATIONS |
| 19 | PURCHASE OF PHILIPS I ² C COMPONENTS |

Clock/calendar with Power Fail Detector

PCF8573

1 FEATURES

- Serial input/output I²C-bus interface for minutes, hours, days and months
- Additional pulse outputs for seconds and minutes
- Alarm register for presetting a time for alarm or remote switching functions
- On-chip power fail detector
- Separate ground pin for the clock allows easy implementation of battery back-up during supply interruption
- Crystal oscillator control (32.768 kHz)
- Low power consumption.

2 GENERAL DESCRIPTION

The PCF8573 is a low threshold, CMOS circuit that functions as a real time clock/calendar. Addresses and data are transferred serially via the two-line bidirectional I²C-bus.

The IC incorporates an addressable time counter and an addressable alarm register for minutes, hours, days and months. Three special control/status flags, COMP, POWF and NODA, are also available. Back-up for the clock during supply interruptions is provided by a 1.2 V nickel cadmium battery. The time base is generated from a 32.768 kHz crystal-controlled oscillator.

3 QUICK REFERENCE DATA

| SYMBOL | PARAMETER | MIN. | TYP. | MAX. | UNIT |
|--------------------|--|------|--------|------|------|
| $V_{DD} - V_{SS1}$ | supply voltage, clock (pin 16 to pin 15) | 1.1 | – | 6.0 | V |
| $V_{DD} - V_{SS2}$ | supply voltage, I ² C-bus (pin 16 to pin 8) | 2.5 | – | 6.0 | V |
| f_{osc} | crystal oscillator frequency | – | 32.768 | – | kHz |

4 ORDERING INFORMATION

| TYPE NUMBER | PACKAGE | | |
|-------------|---------|---|----------|
| | NAME | DESCRIPTION | VERSION |
| PCF8573P | DIP16 | plastic dual in-line package; 16 leads (300 mil); long body | SOT38-1 |
| PCF8573T | SO16 | plastic small outline package; 16 leads; body width 7.5 mm | SOT162-1 |

Clock/calendar with Power Fail Detector

PCF8573

5 BLOCK DIAGRAM

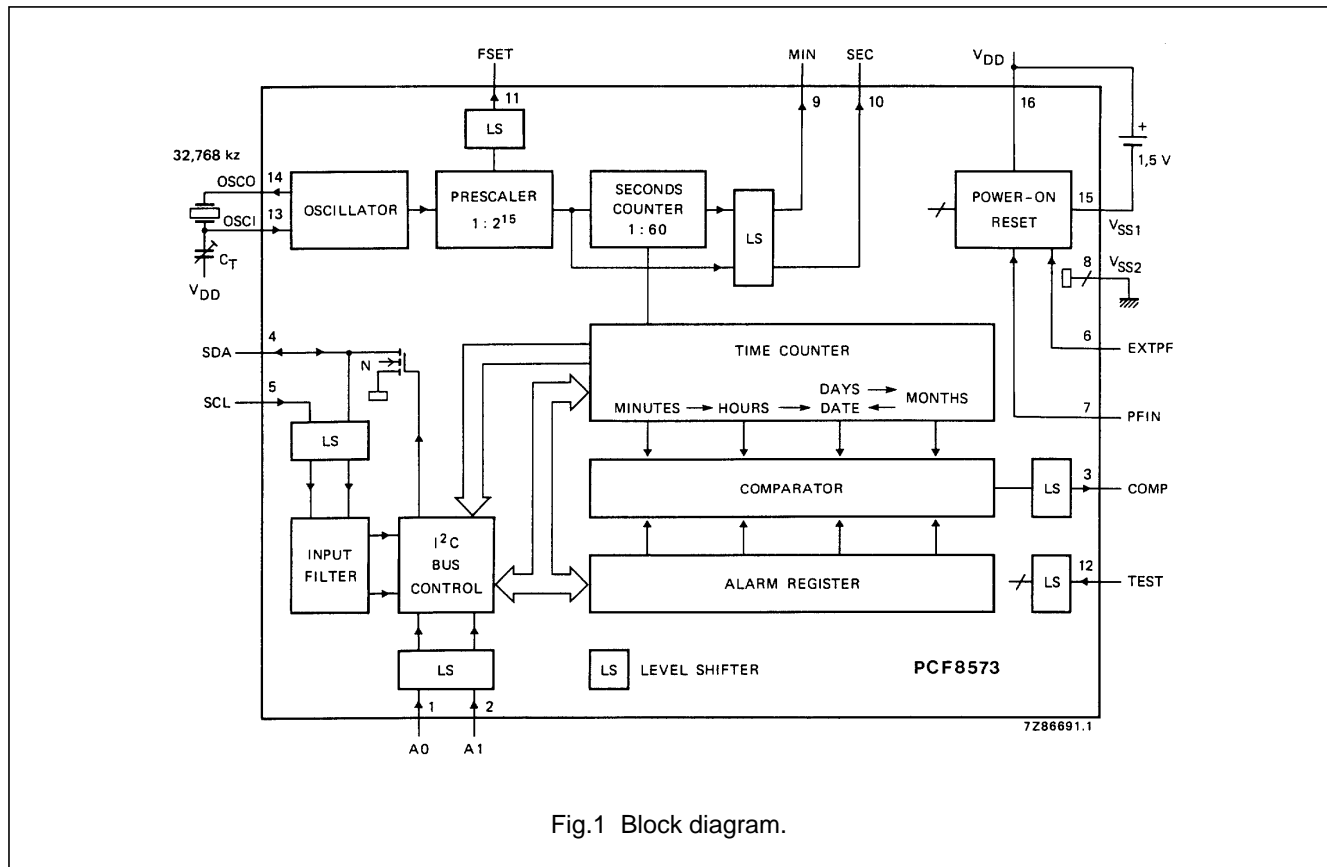

Fig.1 Block diagram.

6 PINNING

| SYMBOL | PIN | DESCRIPTION |
|------------------|-----|---|
| A0 | 1 | address input |
| A1 | 2 | address input |
| COMP | 3 | comparator output |
| SDA | 4 | serial data line; I ² C-bus |
| SCL | 5 | serial clock line; I ² C-bus |
| EXTPF | 6 | enable power fail flag input |
| PFIN | 7 | power fail flag input |
| V _{SS2} | 8 | negative supply 2 (I ² C interface) |
| MIN | 9 | one pulse per minute output |
| SEC | 10 | one pulse per second output |
| FSET | 11 | oscillator tuning output |
| TEST | 12 | test input; connect to V _{SS2} if not in use |
| OSCI | 13 | oscillator input |
| OSCO | 14 | oscillator input/output |
| V _{SS1} | 15 | negative supply 1 (clock) |
| V _{DD} | 16 | common positive supply |

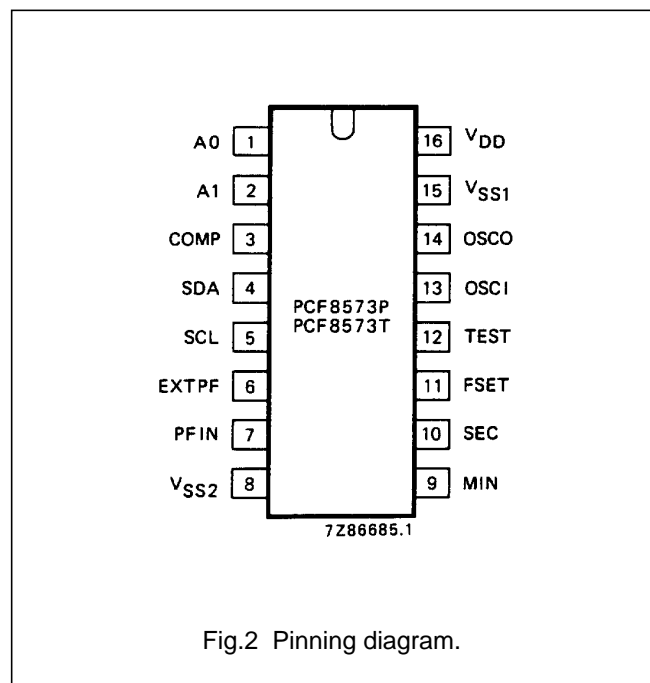

Fig.2 Pinning diagram.

Clock/calendar with Power Fail Detector

PCF8573

7 FUNCTIONAL DESCRIPTION**7.1 Oscillator**

The PCF8573 has an integrated crystal-controlled oscillator which provides the timebase for the prescaler. The frequency is determined by a single 32.76 kHz crystal connected between OSCI and OSCO. A trimmer is connected between OSCI and V_{DD} .

7.2 Prescaler and time counter

The prescaler provides a 128 Hz signal at the FSET output for fine adjustment of the crystal oscillator without loading it. The prescaler also generates a pulse once a second to advance the seconds counter. The carry of the prescaler and the seconds counter are available at the outputs SEC, MIN respectively, and are also readable via the I²C-bus. The mark-to-space ratio of both signals is 1 : 1. The time counter is advanced one count by the falling edge of output signal MIN. A transition from HIGH-to-LOW of output signal SEC triggers MIN to change state. The time counter counts minutes, hours, days and months, and provides a full calendar function which needs to be corrected only once every four years - to allow for leap-year. Cycle lengths are shown in Table 1.

7.3 Alarm register

The alarm register is a 24-bit memory. It stores the time-point for the next setting of the status flag COMP. Details of writing and reading of the alarm register are included in the description of the characteristics of the I²C-bus.

7.4 Comparator

The comparator compares the contents of the alarm register and the time counter, each with a length of 24 bits. When these contents are equal the flag COMP will be set 4 ms after the falling edge of MIN. This set condition occurs once at the beginning of each minute. This information is latched, but can be cleared by an instruction via the I²C-bus. A clear instruction may be transmitted immediately after the flag is set and will be executed. Flag COMP information is also available at the output COMP. The comparison may be based upon hours and minutes only if the internal flag NODA (no date) is set. Flag NODA can be set and cleared by separate instructions via the I²C-bus, but it is undefined until the first set or clear instruction has been received. Both COMP and NODA flags are readable via the I²C-bus.

Table 1 Cycle length of the time counter

| UNIT | NUMBER OF BITS | COUNTING CYCLE | CARRY FOR FOLLOWING UNIT | CONTENT OF MONTH COUNTER |
|---------------------|----------------|----------------|--------------------------|--------------------------|
| minutes | 7 | 00 to 59 | 59 → 00 | |
| hours | 6 | 00 to 23 | 23 → 00 | |
| days ⁽¹⁾ | 6 | 01 to 28 | 28 → 01 | 2 (note 1) |
| | | | or 29 → 01 | 2 (note 1) |
| | | 01 to 30 | 30 → 01 | 4, 6, 9, 11 |
| | | 01 to 31 | 31 → 01 | 1, 3, 5, 7, 8, 10, 12 |
| months | 5 | 01 to 12 | 12 → 01 | |

Note

1. During February of a leap-year the 'Time Counter Days' may be set to 29 by directly writing into it using the 'execute address' function. Leap-years must be tracked by the system software.

Clock/calendar with Power Fail Detector

PCF8573

7.5 Power on/power fail detection

If the voltage $V_{DD} - V_{SS1}$ falls below a certain value the operation of the clock becomes undefined. Thus a warning signal is required to indicate that faultless operation of the clock is not guaranteed. This information is latched in a flag called POWF (Power Fail) and remains latched after restoration of the correct supply voltage until a write procedure with EXECUTE ADDRESS has been received. The flag POWF can be set by an internally generated power fail level-discriminator signal for application with $(V_{DD} - V_{SS1})$ greater than V_{TH1} , or by an externally generated power fail signal for application with $(V_{DD} - V_{SS1})$ less than V_{TH1} . The external signal must be applied to the input PFIN. The input stage operates with signals of slow rise and fall times. Internally or externally controlled POWF can be selected by input EXTPF as shown in Table 2.

Table 2 Power fail selection

| EXTPF ⁽¹⁾ | PFIN ⁽¹⁾ | FUNCTION |
|----------------------|---------------------|---------------------------------|
| 0 | 0 | power fail is sensed internally |
| 0 | 1 | test mode |
| 1 | 0 | power fail is sensed externally |
| 1 | 1 | no power fail sensed |

Note

- 0 = V_{SS1} (LOW); 1 = V_{DD} (HIGH).

The external power fail control operates by absence of the $V_{DD} - V_{SS2}$ supply. Therefore the input levels applied to PFIN and EXTPF must be within the range of $V_{DD} - V_{SS1}$. A LOW level at PFIN indicates a power fail. POWF is readable via the I²C-bus. A power-on reset for the I²C-bus control is generated on-chip when the supply voltage $V_{DD} - V_{SS2}$ is less than V_{TH2} .

7.6 Interface level shifters

The level shifters adjust the 5 V operating voltage ($V_{DD} - V_{SS2}$) of the microcontroller to the internal supply voltage ($V_{DD} - V_{SS1}$) of the clock/calendar. The oscillator and counter are not influenced by the $V_{DD} - V_{SS2}$ supply voltage. If the voltage $V_{DD} - V_{SS2}$ is absent ($V_{DD} = V_{SS2}$) the output signal of the level shifter is HIGH because V_{DD} is the common node of the $V_{DD} - V_{SS2}$ and the $V_{DD} - V_{SS1}$ supplies. Because the level shifters invert the input signals, the internal circuit behaves as if a LOW signal is present on the inputs. FSET, SEC, MIN and COMP are CMOS push-pull output stages. The driving capability of these outputs is lost when the supply voltage $V_{DD} - V_{SS2} = 0$.

Clock/calendar with Power Fail Detector

PCF8573

8 CHARACTERISTICS OF THE I²C-BUS

The I²C-bus is for 2-way, 2-line communication between different ICs or modules. The two lines are a serial data line (SDA) and a serial clock line (SCL). Both lines must be connected to a positive supply via a pull-up resistor when connected to the output stages of a device. Data transfer may be initiated only when the bus is not busy.

8.1 Bit transfer (see Fig.3)

One data bit is transferred during each clock pulse. The data on the SDA line must remain stable during the HIGH period of the clock pulse as changes in the data line at this time will be interpreted as control signals.

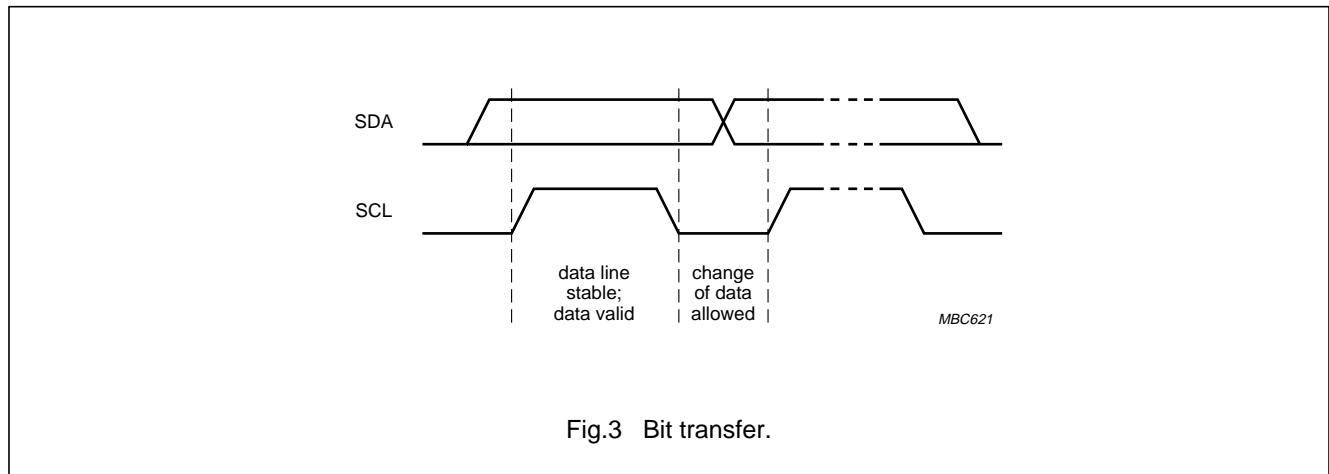

8.2 Start and stop conditions (see Fig.4)

Both data and clock lines remain HIGH when the bus is not busy. A HIGH-to-LOW transition of the data line, while the clock is HIGH is defined as the start condition (S). A LOW-to-HIGH transition of the data line while the clock is HIGH is defined as the stop condition (P).

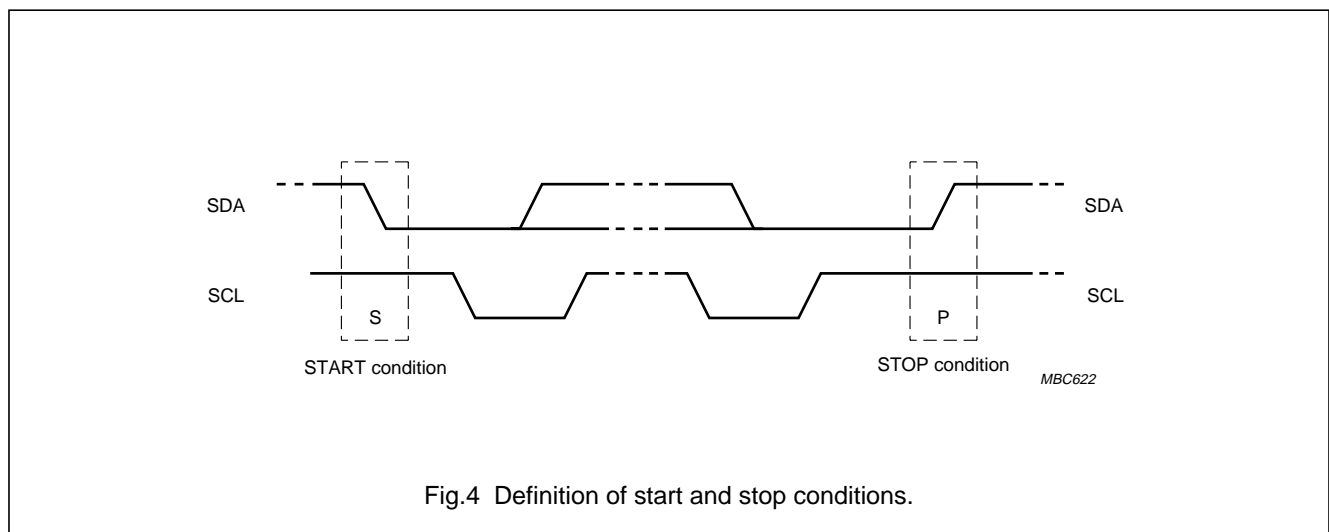

Clock/calendar with Power Fail Detector

PCF8573

8.3 System configuration (see Fig.5)

A device generating a message is a 'transmitter', a device receiving a message is the 'receiver'. The device that controls the message is the 'master' and the devices which are controlled by the master are the 'slaves'.

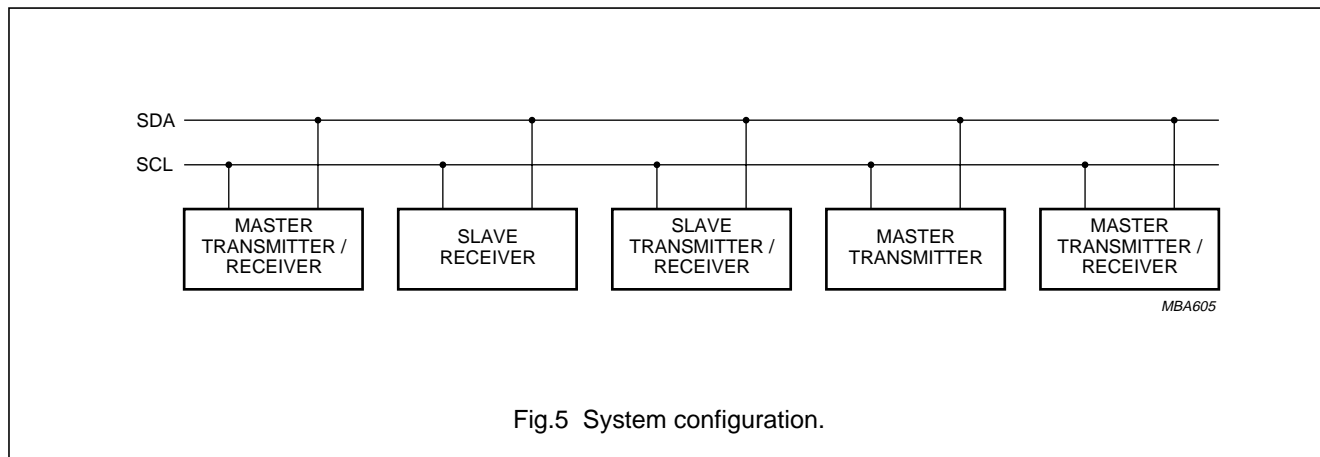

Fig.5 System configuration.

8.4 Acknowledge (see Fig.6)

The number of data bytes transferred between the start and stop conditions from transmitter to receiver is unlimited. Each byte of eight bits is followed by an acknowledge bit. The acknowledge bit is a HIGH level signal put on the bus by the transmitter during which time the master generates an extra acknowledge related clock pulse. A slave receiver which is addressed must generate an acknowledge after the reception of each byte. Also a master receiver must generate an acknowledge after the reception of each byte that has been clocked out of the slave transmitter.

The device that acknowledges must pull down the SDA line during the acknowledge clock pulse, so that the SDA line is stable LOW during the HIGH period of the acknowledge related clock pulse (set-up and hold times must be taken into consideration). A master receiver must signal an end of data to the transmitter by **not** generating an acknowledge on the **last byte** that has been clocked out of the slave. In this event the transmitter must leave the data line HIGH to enable the master to generate a stop condition, see Figs. 9 and 10.

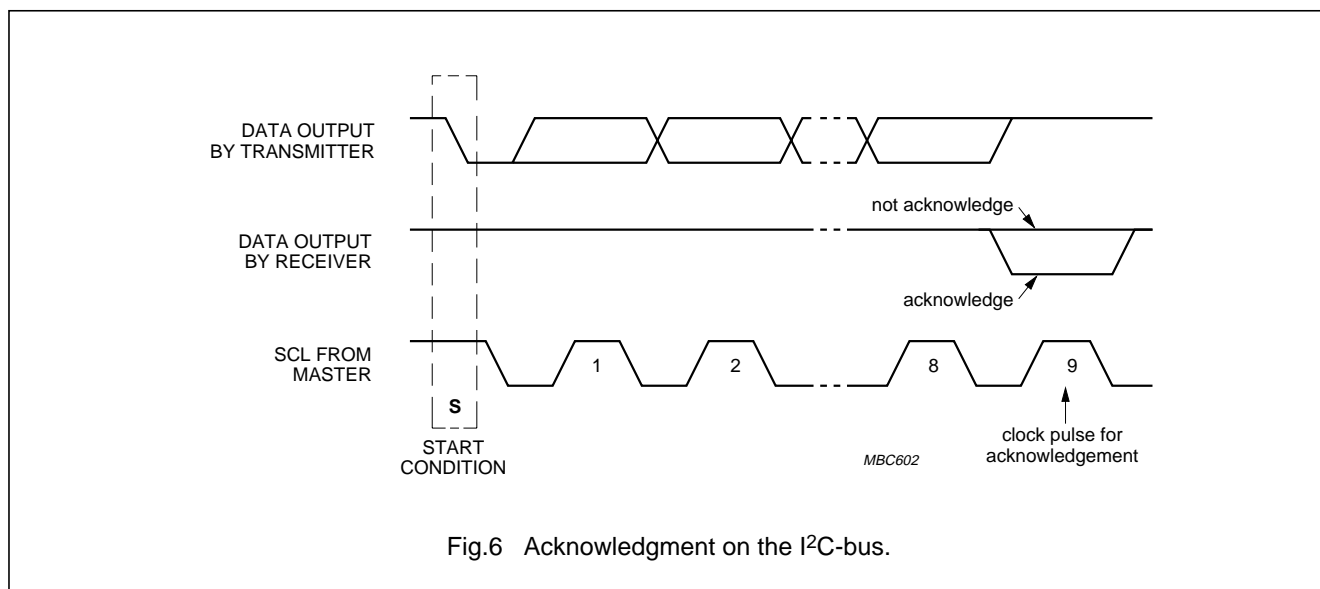

Fig.6 Acknowledgment on the I²C-bus.

Clock/calendar with Power Fail Detector

PCF8573

9 I²C-BUS PROTOCOL

9.1 Addressing

Before any data is transmitted on the I²C-bus, the device which should respond is addressed first. The addressing is always done with the first byte transmitted after the start procedure.

The clock/calendar acts as a slave receiver or slave transmitter. Therefore the clock signal SCL is only an input signal, but the data signal SDA is a bidirectional line.

The clock/calendar slave address is shown in Fig.7. Bits A0 and A1 correspond to the two hardware address pins A0 and A1. Connecting these to V_{DD} or V_{SS} allows the device to have 1 of 4 different addresses.

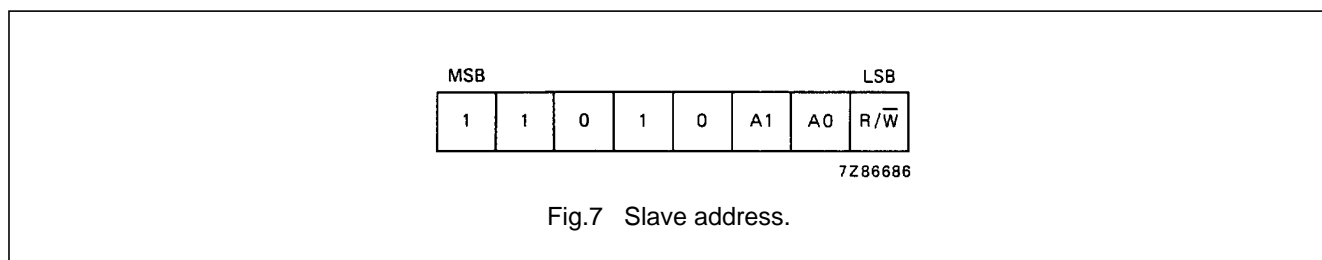

9.2 Clock/calendar READ/WRITE cycles

The I²C-bus configuration for different clock/calendar READ and WRITE cycles is shown in Figs 8, 9 and 10.

The write cycle is used to set the time counter, the alarm register and the flags. The transmission of the clock/calendar address is followed by the MODE-POINTER-word which contains a CONTROL-nibble (Table 3) and an ADDRESS-nibble (Table 4). The ADDRESS-nibble is valid only if the preceding CONTROL-nibble is set to EXECUTE ADDRESS. The third transmitted word contains the data to be written into the time counter or alarm register.

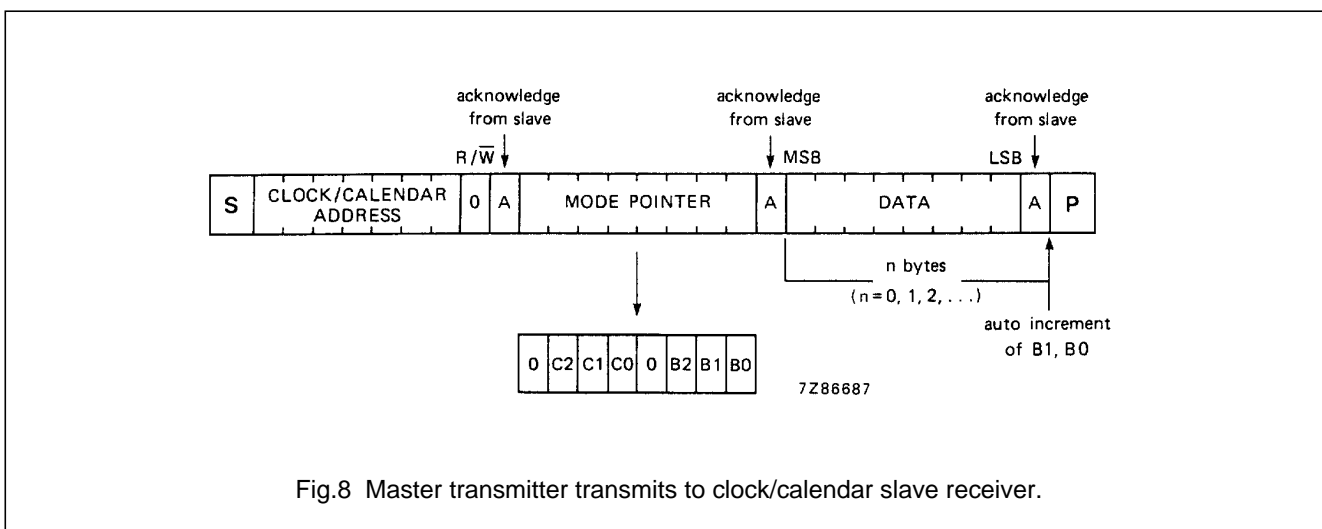

Clock/calendar with Power Fail Detector

PCF8573

Table 3 MODE-POINTER-word, CONTROL-nibble (bits 8, 7, 6 and 5)

| BIT 8 | C2 | C1 | C0 | FUNCTION |
|-------|----|----|----|--|
| 0 | 0 | 0 | 0 | execute address |
| 0 | 0 | 0 | 1 | read control/status flags |
| 0 | 0 | 1 | 0 | reset prescaler, including seconds counter; without carry for minute counter |
| 0 | 0 | 1 | 1 | time adjust, with carry for minute counter (note 1) |
| 0 | 1 | 0 | 0 | reset NODA flag |
| 0 | 1 | 0 | 1 | set NODA flag |
| 0 | 1 | 1 | 0 | reset COMP flag |

Note

1. If the seconds counter is below 30 there is no carry. This causes a time adjustment of max. –30 s. From the count 30 there is a carry which adjusts the time by max. +30 s.

Table 4 MODE-POINTER-word, ADDRESS-nibble (bits 4, 3, 2 and 1)

| BIT 4 | B2 | B1 | B0 | ADDRESSED TO: |
|-------|----|----|----|------------------------|
| 0 | 0 | 0 | 0 | time counter hours |
| 0 | 0 | 0 | 1 | time counter minutes |
| 0 | 0 | 1 | 0 | time counter days |
| 0 | 0 | 1 | 1 | time counter months |
| 0 | 1 | 0 | 0 | alarm register hours |
| 0 | 1 | 0 | 1 | alarm register minutes |
| 0 | 1 | 1 | 0 | alarm register days |
| 0 | 1 | 1 | 1 | alarm register months |

At the end of each data word the address bits B1, B0 will be incremented automatically provided the preceding CONTROL-nibble is set to EXECUTE ADDRESS. There is no carry to B2.

Table 5 shows the placement of the BCD upper and lower digits in the DATA byte for writing into the addressed part of the time counter and alarm register respectively.

Table 6 shows the acknowledgement response of the clock calendar as a slave receiver.

Table 5 Placement of BCD digits in the DATA byte; note 1

| MSB | | | | DATA | | | | LSB | ADDRESSED TO: |
|-------------|----|----|----|-------------|----|----|----|---------|---------------|
| UPPER DIGIT | | | | LOWER DIGIT | | | | | |
| UD | UC | UB | UA | LD | LC | LB | LA | | |
| X | X | D | D | D | D | D | D | hours | |
| X | D | D | D | D | D | D | D | minutes | |
| X | X | D | D | D | D | D | D | days | |
| X | X | X | D | D | D | D | D | months | |

Note

1. 'X' is the don't care bit; 'D' is the data bit.

Clock/calendar with Power Fail Detector

PCF8573

Acknowledgement response of the PCF8573 as slave-receiver is shown in Table 6. Note that data is only associated with the 'execute address' function where C0, C1, C2 = 0, 0, 0.

Table 6 Slave receiver acknowledgement; note 1

| MODE POINTER | | | | | | | | ACKNOWLEDGE ON BYTE: | | |
|--------------|----|----|----|-------|----|----|----|----------------------|--------------|------|
| BIT 8 | C2 | C1 | C0 | BIT 4 | B2 | B1 | B0 | ADDRESS | MODE POINTER | DATA |
| 0 | 0 | 0 | 0 | 0 | X | X | X | yes | yes | yes |
| 0 | 0 | 0 | 0 | 1 | X | X | X | yes | no | no |
| 0 | 0 | 0 | 1 | X | X | X | X | yes | yes | no |
| 0 | 0 | 1 | 0 | X | X | X | X | yes | yes | no |
| 0 | 0 | 1 | 1 | X | X | X | X | yes | yes | no |
| 0 | 1 | 0 | 0 | X | X | X | X | yes | yes | no |
| 0 | 1 | 0 | 1 | X | X | X | X | yes | yes | no |
| 0 | 1 | 1 | 0 | X | X | X | X | yes | yes | no |
| 0 | 1 | 1 | 1 | X | X | X | X | yes | no | no |
| 1 | X | X | X | X | X | X | X | yes | no | no |

Note

- 'X' is 'don't care'.

To read the addressed part of the time counter and alarm register, plus information from specified control/status flags, the BCD digits in the DATA byte are organized as shown in Table 7.

The status of the CONTROL-nibble of the MODE-POINTER-WORD (C2, C1, C0) remains unchanged until re-written.

Table 7 Organization of the BCD digits in the DATA byte; note 1

| MSB | | | | DATA | | | | LSB | ADDRESSED TO: |
|-------------|----|----|----|-------------|------|------|------|----------------------|---------------|
| UPPER DIGIT | | | | LOWER DIGIT | | | | | |
| UD | UC | UB | UA | LD | LC | LB | LA | | |
| 0 | 0 | D | D | D | D | D | D | hours | |
| 0 | D | D | D | D | D | D | D | minutes | |
| 0 | 0 | D | D | D | D | D | D | days | |
| 0 | 0 | 0 | D | D | D | D | D | months | |
| 0 | 0 | 0 | m | s | NODA | COMP | POWF | control/status flags | |

Note

- 'D' is the data bit; 'm' = minutes; 's' = seconds.

Clock/calendar with Power Fail Detector

PCF8573

10 LIMITING VALUES

In accordance with the Absolute Maximum Rating System (IEC 134).

| SYMBOL | PARAMETER | MIN. | MAX. | UNIT |
|--------------------|--|-----------------|----------------|--------------------|
| $V_{DD} - V_{SS1}$ | supply voltage (pin 16 to pin 15) | -0.3 | +8.0 | V |
| $V_{DD} - V_{SS2}$ | supply voltage (pin 16 to pin 8) | -0.3 | +8.0 | V |
| V_I | input voltage | | | |
| | pins 4 and 5 (with input impedance of minimum 500 Ω) | $V_{SS2} - 0.8$ | $V_{DD} + 0.8$ | V |
| | pins 6, 7, 13 and 14 | $V_{SS1} - 0.6$ | $V_{DD} + 0.6$ | V |
| | any other pin | $V_{SS2} - 0.6$ | $V_{DD} + 0.6$ | V |
| I_I | DC input current | - | 10 | mA |
| I_O | DC output current | - | 10 | mA |
| P_{tot} | total power dissipation per package | - | 200 | mW |
| P_O | power dissipation per output | - | 100 | mW |
| T_{amb} | operating ambient temperature | -40 | +85 | $^{\circ}\text{C}$ |
| T_{stg} | storage temperature | -55 | +125 | $^{\circ}\text{C}$ |

11 HANDLING

Inputs and outputs are protected against electrostatic charge in normal handling. However, to be totally safe, it is desirable to take normal precautions appropriate to handling MOS devices. Advice can be found in Data Handbook IC12 under "Handling MOS Devices".

Clock/calendar with Power Fail Detector

PCF8573

12 DC CHARACTERISTICS

 $V_{SS2} = 0\text{ V}$; $T_{amb} = -40$ to $+85\text{ }^{\circ}\text{C}$ unless otherwise specified. Typical values at $T_{amb} = 25\text{ }^{\circ}\text{C}$.

| SYMBOL | PARAMETER | CONDITIONS | MIN. | TYP. | MAX. | UNIT |
|--|---|--|-----------------------|------|-----------------------|---------------|
| Supply | | | | | | |
| $V_{DD} - V_{SS2}$ | supply voltage (I ² C interface) | | 2.5 | 5.0 | 6.0 | V |
| $V_{DD} - V_{SS1}$ | supply voltage (clock) | $t_{HD}; DAT \geq 300\text{ ns}$ | 1.1 | 1.5 | $V_{DD} - V_{SS2}$ | V |
| I_{SS1} | supply current at V_{SS1} (pin 15) | see Fig.11 $V_{DD} - V_{SS1} = 1.5\text{ V}$ | – | –3 | –10 | μA |
| | | $V_{DD} - V_{SS1} = 5\text{ V}$ | – | –12 | –50 | μA |
| I_{SS2} | supply current at V_{SS2} (pin 8) | $V_{DD} - V_{SS2} = 5\text{ V}$; $I_O = 0$ all outputs | – | – | –50 | μA |
| Input SCL, input/output SDA | | | | | | |
| V_{IL} | LOW level input voltage | | – | – | $0.3V_{DD}$ | V |
| V_{IH} | HIGH level input voltage | | $0.7V_{DD}$ | – | – | V |
| I_{LI} | input leakage current | $V_I = V_{SS2}$ or V_{DD} | –1 | – | +1 | μA |
| C_i | input capacitance | | – | – | 7 | pF |
| Inputs A0, A1, TEST | | | | | | |
| V_{IL} | LOW level input voltage | | – | – | $0.2V_{DD}$ | V |
| V_{IH} | HIGH level input voltage | | $0.7V_{DD}$ | – | – | V |
| I_{LI} | input leakage current | $V_I = V_{SS2}$ or V_{DD} | –250 | – | +250 | nA |
| Inputs EXTPF, PFIN | | | | | | |
| V_{IL} | LOW level input voltage | | 0 | – | $0.2V_{DD} - V_{SS1}$ | V |
| V_{IH} | HIGH level input voltage | | $0.7V_{DD} - V_{SS1}$ | – | – | V |
| I_{LI} | input leakage current | $V_I = V_{SS1}$ to V_{DD} | –1.0 | – | +1.0 | μA |
| | | $V_I = V_{SS1}$ to V_{DD} ; $T_{amb} = 25\text{ }^{\circ}\text{C}$ | –0.1 | – | +0.1 | μA |
| Output SDA (n channel open-drain) | | | | | | |
| V_{OL} | LOW level output voltage | output ON; $I_O = 3\text{ mA}$; $V_{DD} - V_{SS2} = 2.5$ to 6 V | – | – | 0.4 | V |
| I_{LI} | input leakage current | $V_{DD} - V_{SS2} = 6\text{ V}$; $V_O = 6\text{ V}$ | –1.0 | – | +1.0 | μA |
| Output SEC, MIN, COMP, FSET (normal buffer outputs) | | | | | | |
| V_{OL} | LOW level output voltage | $V_{DD} - V_{SS2} = 2.5\text{ V}$; $I_O = 0.3\text{ mA}$ | – | – | 0.4 | V |
| | | $V_{DD} - V_{SS2} = 4$ to 6 V ; $I_O = 1.6\text{ mA}$ | – | – | 0.4 | V |
| V_{OH} | HIGH level output voltage | $V_{DD} - V_{SS2} = 2.5\text{ V}$; $I_O = -0.1\text{ mA}$ | $V_{DD} - 0.4$ | – | – | V |
| | | $V_{DD} - V_{SS2} = 4$ to 6 V ; $I_O = -0.5\text{ mA}$ | $V_{DD} - 0.4$ | – | – | V |

Clock/calendar with Power Fail Detector

PCF8573

| SYMBOL | PARAMETER | CONDITIONS | MIN. | TYP. | MAX. | UNIT |
|------------------------------------|-------------------------|------------|------|------|------|------|
| Internal threshold voltages | | | | | | |
| V_{TH1} | Power failure detection | | 1 | 1.2 | 1.4 | V |
| V_{TH2} | Power-on reset | | 1.5 | 2.0 | 2.5 | V |

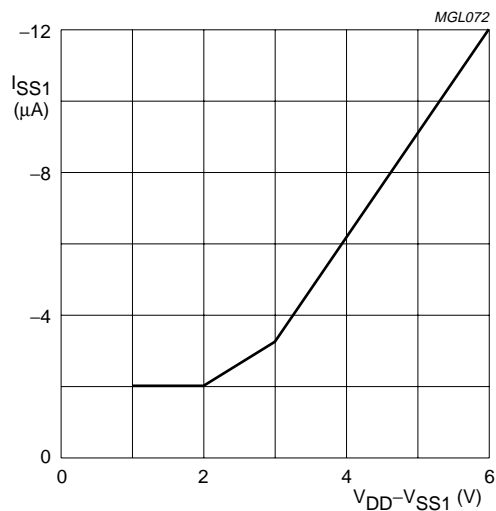

Fig.11 Typical supply current (I_{SS1}) as a function of clock supply voltage ($V_{DD} - V_{SS1}$) at $T_{amb} = -40$ to $+85$ °C.

Clock/calendar with Power Fail Detector

PCF8573

13 AC CHARACTERISTICS

$V_{SS2} = 0\text{ V}$; $T_{\text{amb}} = -40\text{ to }+85\text{ }^{\circ}\text{C}$ unless otherwise specified. Typical values at $T_{\text{amb}} = +25\text{ }^{\circ}\text{C}$.

| SYMBOL | PARAMETER | CONDITIONS | MIN. | TYP. | MAX. | UNIT |
|--|-----------------------------------|---|------|--------------------|----------|---------------|
| Rise and fall times of input signals | | | | | | |
| t_r | rise time | input EXTPF | – | – | 1 | μs |
| | | input PFIN | – | – | ∞ | μs |
| | | all other inputs (levels between V_{IL} and V_{IH}) | – | – | 1 | μs |
| t_f | fall time | input EXTPF | – | – | 1 | μs |
| | | input PFIN | – | – | ∞ | μs |
| | | all other inputs (levels between V_{IL} and V_{IH}) | – | – | 0.3 | μs |
| Oscillator | | | | | | |
| C_{osc} | integrated oscillator capacitance | | – | 40 | – | pF |
| R_f | oscillator feedback resistance | | – | 3 | – | M Ω |
| Δf_{osc} | oscillator stability | $\Delta(V_{DD} - V_{SS1}) = 100\text{ mV}$; $T_{\text{amb}} = 25\text{ }^{\circ}\text{C}$; $(V_{DD} - V_{SS1}) = 1.55\text{ V}$ | – | 2×10^{-7} | – | |
| Quartz crystal parameters (f = 32.768 kHz) | | | | | | |
| R_s | series resistance | | – | – | 40 | k Ω |
| C_L | parallel load capacitance | | – | 10 | – | pF |
| C_T | trimmer capacitance | | 5 | – | 25 | pF |
| I²C-bus timing (see Fig.12; notes 1 and 2) | | | | | | |
| f_{SCL} | SCL clock frequency | | – | – | 100 | kHz |
| t_{SP} | tolerable spike width on bus | | – | – | 100 | ns |
| t_{BUF} | bus free time | | 4.7 | – | – | μs |
| $t_{\text{SU;STA}}$ | START condition set-up time | | 4.7 | – | – | μs |
| $t_{\text{HD;STA}}$ | START condition hold time | | 4.0 | – | – | μs |
| t_{LOW} | SCL LOW time | | 4.7 | – | – | μs |
| t_{HIGH} | SCL HIGH time | | 4.0 | – | – | μs |
| t_r | SCL and SDA rise time | | – | – | 1.0 | μs |
| t_f | SCL and SDA fall time | | – | – | 0.3 | μs |
| $t_{\text{SU;DAT}}$ | data set-up time | | 250 | – | – | ns |
| $t_{\text{HD;DAT}}$ | data hold time | | 0 | – | – | ns |
| $t_{\text{VD;DAT}}$ | SCL LOW to data out valid | | – | – | 3.4 | μs |
| $t_{\text{SU;STO}}$ | STOP condition set-up time | | 4.0 | – | – | μs |

Notes

- All timing values are valid within the operating supply voltage and ambient temperature range and reference to V_{IL} and V_{IH} with an input voltage swing of V_{SS} to V_{DD} .
- A detailed description of the I²C-bus specification, with applications, is given in brochure "The I²C-bus and how to use it". This brochure may be ordered using the code 9398 393 40011.

Clock/calendar with Power Fail Detector

PCF8573

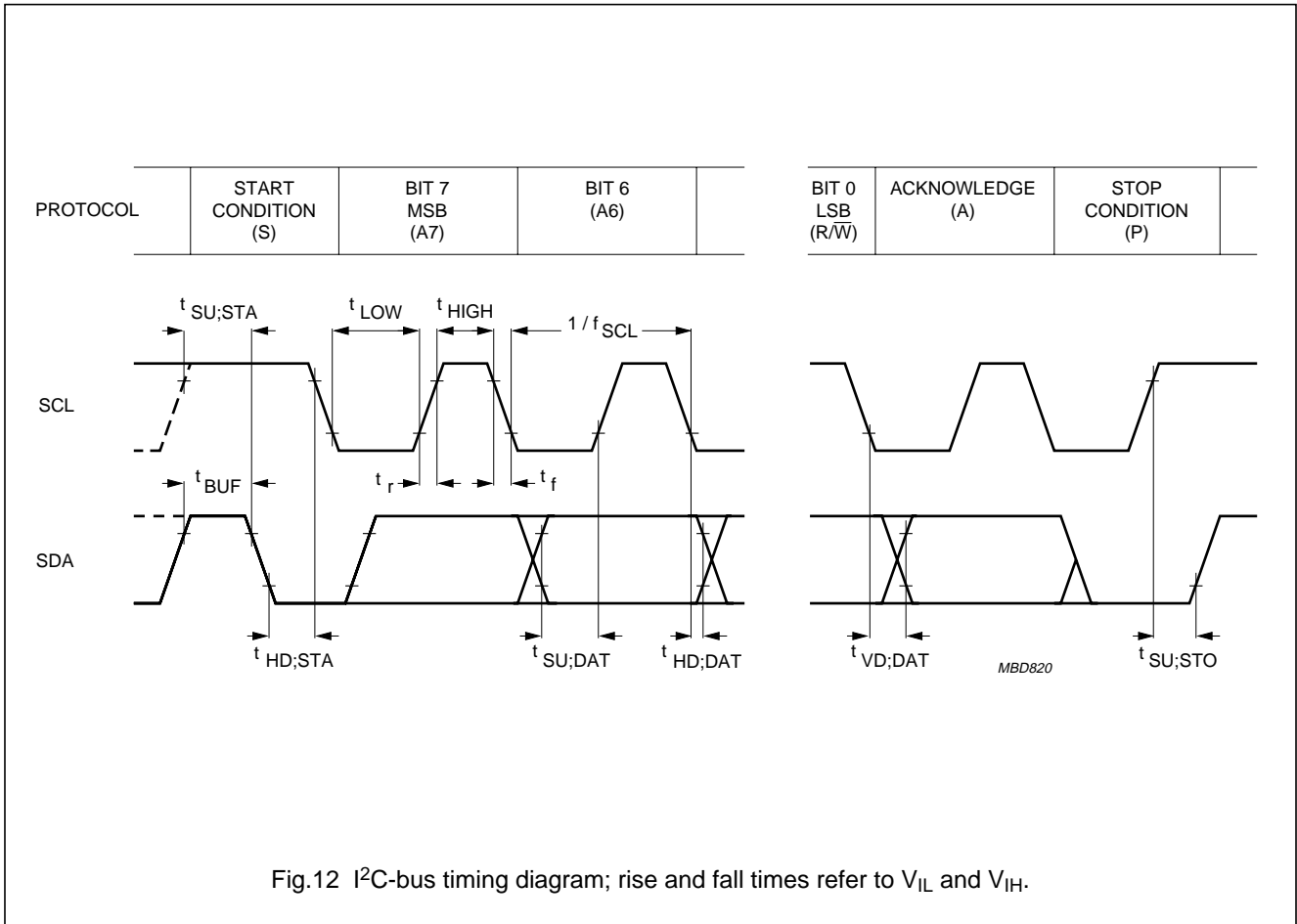

Clock/calendar with Power Fail Detector

PCF8573

14 APPLICATION INFORMATION

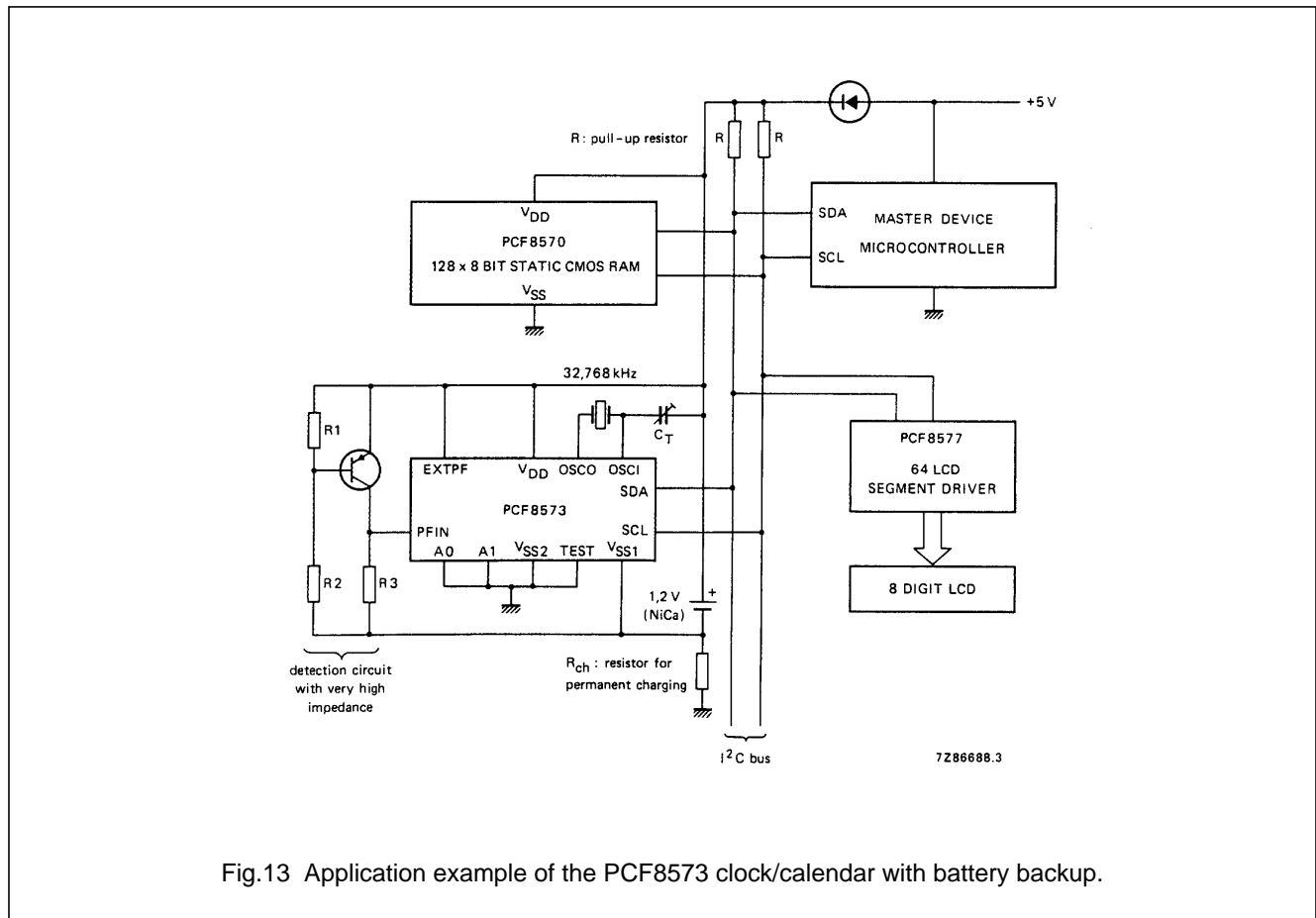

Fig.13 Application example of the PCF8573 clock/calendar with battery backup.

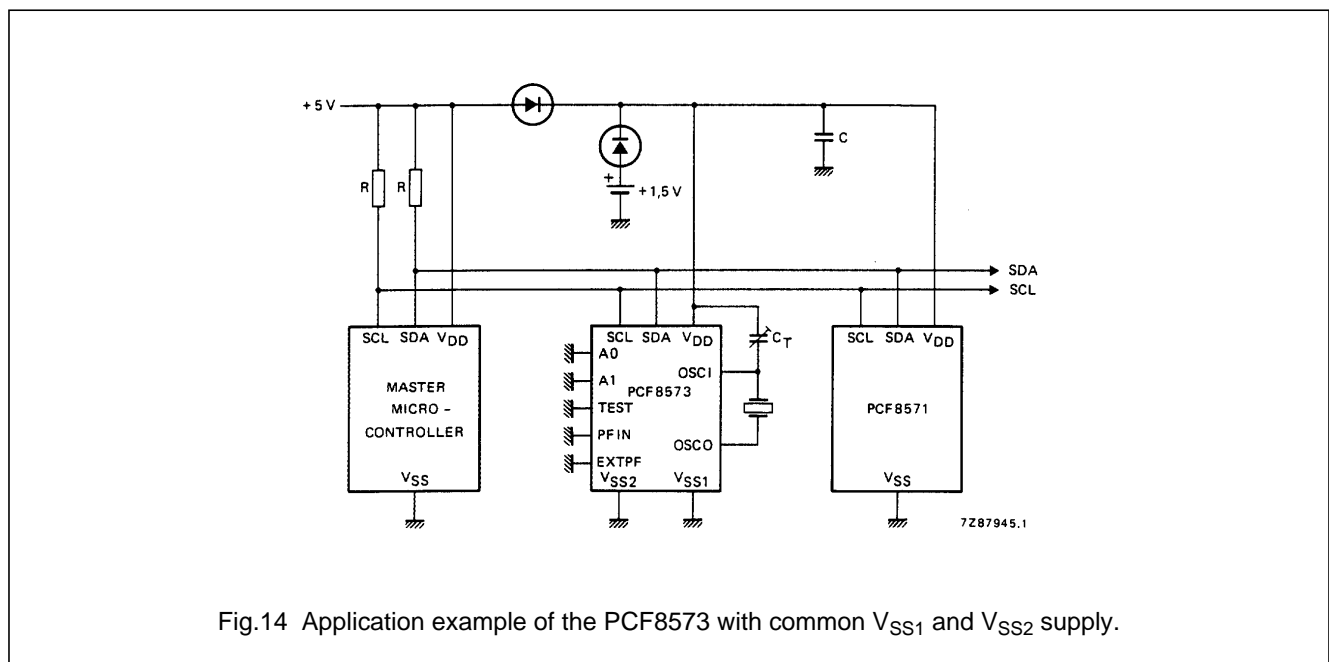

Fig.14 Application example of the PCF8573 with common V_{SS1} and V_{SS2} supply.

Clock/calendar with Power Fail Detector

PCF8573

15 PACKAGE OUTLINES

DIP16: plastic dual in-line package; 16 leads (300 mil); long body

SOT38-1

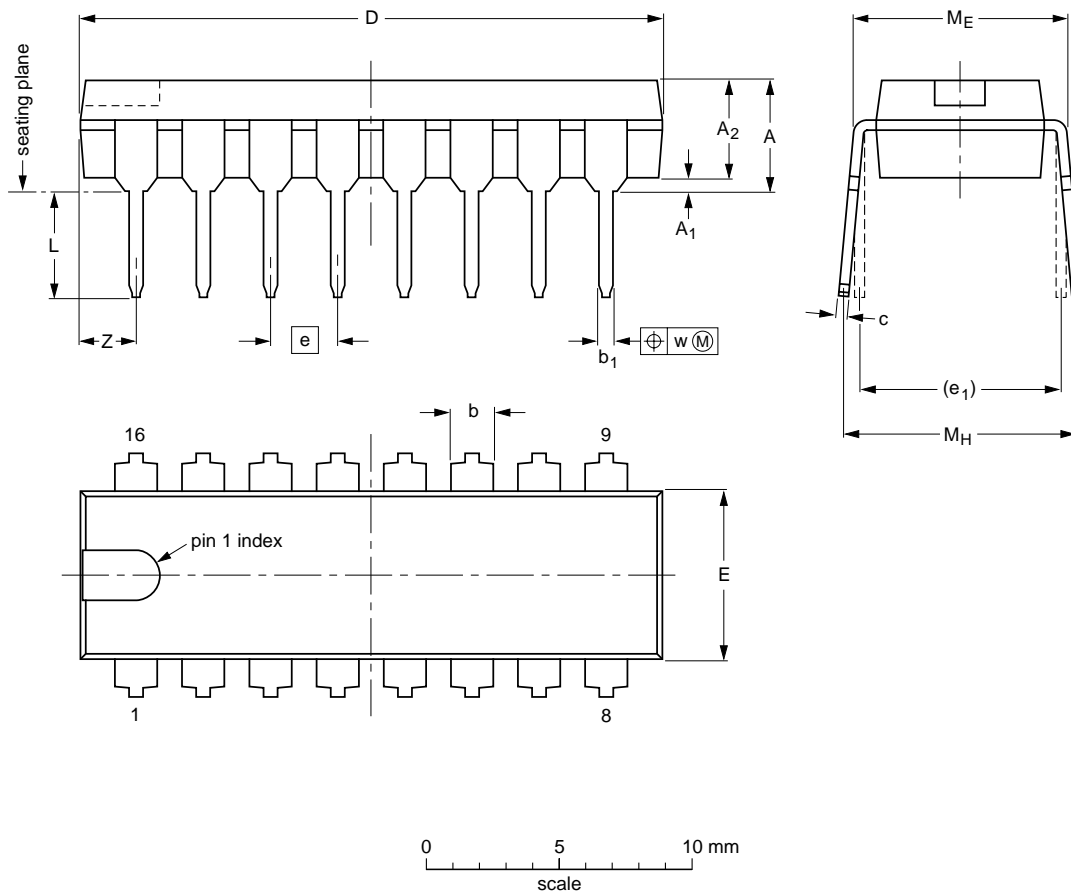

DIMENSIONS (inch dimensions are derived from the original mm dimensions)

| UNIT | A max. | A ₁ min. | A ₂ max. | b | b ₁ | c | D ⁽¹⁾ | E ⁽¹⁾ | e | e ₁ | L | M _E | M _H | w | Z ⁽¹⁾ max. |
|--------|--------|---------------------|---------------------|----------------|----------------|----------------|------------------|------------------|------|----------------|--------------|----------------|----------------|-------|-----------------------|
| mm | 4.7 | 0.51 | 3.7 | 1.40 1.14 | 0.53 0.38 | 0.32 0.23 | 21.8 21.4 | 6.48 6.20 | 2.54 | 7.62 | 3.9 3.4 | 8.25 7.80 | 9.5 8.3 | 0.254 | 2.2 |
| inches | 0.19 | 0.020 | 0.15 | 0.055 0.045 | 0.021 0.015 | 0.013 0.009 | 0.86 0.84 | 0.26 0.24 | 0.10 | 0.30 | 0.15 0.13 | 0.32 0.31 | 0.37 0.33 | 0.01 | 0.087 |

Note

1. Plastic or metal protrusions of 0.25 mm maximum per side are not included.

| OUTLINE VERSION | REFERENCES | | | | EUROPEAN PROJECTION | ISSUE DATE |
|-----------------|------------|----------|------|--|---------------------|----------------------|
| | IEC | JEDEC | EIAJ | | | |
| SOT38-1 | 050G09 | MO-001AE | | | | 92-10-02 95-01-19 |

Clock/calendar with Power Fail Detector

PCF8573

SOT16: plastic small outline package; 16 leads; body width 7.5 mm

SOT162-1

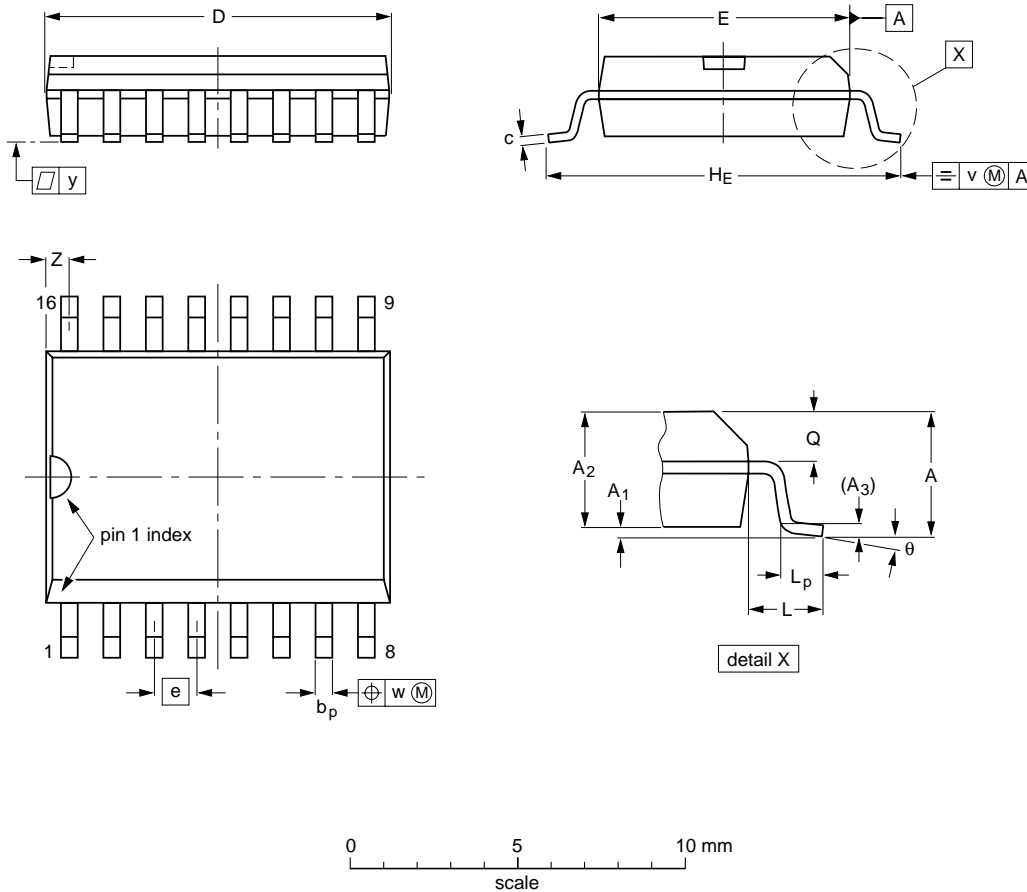

DIMENSIONS (inch dimensions are derived from the original mm dimensions)

| UNIT | A max. | A ₁ | A ₂ | A ₃ | b _p | c | D ⁽¹⁾ | E ⁽¹⁾ | e | H _E | L | L _p | Q | v | w | y | Z ⁽¹⁾ | θ |
|--------|--------|----------------|----------------|----------------|----------------|----------------|------------------|------------------|-------|----------------|-------|----------------|----------------|------|------|-------|------------------|----------|
| mm | 2.65 | 0.30 0.10 | 2.45 2.25 | 0.25 | 0.49 0.36 | 0.32 0.23 | 10.5 10.1 | 7.6 7.4 | 1.27 | 10.65 10.00 | 1.4 | 1.1 0.4 | 1.1 1.0 | 0.25 | 0.25 | 0.1 | 0.9 0.4 | 8° 0° |
| inches | 0.10 | 0.012 0.004 | 0.096 0.089 | 0.01 | 0.019 0.014 | 0.013 0.009 | 0.41 0.40 | 0.30 0.29 | 0.050 | 0.42 0.39 | 0.055 | 0.043 0.016 | 0.043 0.039 | 0.01 | 0.01 | 0.004 | 0.035 0.016 | |

Note

1. Plastic or metal protrusions of 0.15 mm maximum per side are not included.

| OUTLINE VERSION | REFERENCES | | | | EUROPEAN PROJECTION | ISSUE DATE |
|-----------------|------------|----------|------|--|---------------------|----------------------|
| | IEC | JEDEC | EIAJ | | | |
| SOT162-1 | 075E03 | MS-013AA | | | | 92-11-17 95-01-24 |

Clock/calendar with Power Fail Detector

PCF8573

16 SOLDERING

16.1 Introduction

There is no soldering method that is ideal for all IC packages. Wave soldering is often preferred when through-hole and surface mounted components are mixed on one printed-circuit board. However, wave soldering is not always suitable for surface mounted ICs, or for printed-circuits with high population densities. In these situations reflow soldering is often used.

This text gives a very brief insight to a complex technology. A more in-depth account of soldering ICs can be found in our *"IC Package Databook"* (order code 9398 652 90011).

16.2 DIP

16.2.1 SOLDERING BY DIPPING OR BY WAVE

The maximum permissible temperature of the solder is 260 °C; solder at this temperature must not be in contact with the joint for more than 5 seconds. The total contact time of successive solder waves must not exceed 5 seconds.

The device may be mounted up to the seating plane, but the temperature of the plastic body must not exceed the specified maximum storage temperature ($T_{stg\ max}$). If the printed-circuit board has been pre-heated, forced cooling may be necessary immediately after soldering to keep the temperature within the permissible limit.

16.2.2 REPAIRING SOLDERED JOINTS

Apply a low voltage soldering iron (less than 24 V) to the lead(s) of the package, below the seating plane or not more than 2 mm above it. If the temperature of the soldering iron bit is less than 300 °C it may remain in contact for up to 10 seconds. If the bit temperature is between 300 and 400 °C, contact may be up to 5 seconds.

16.3 SO

16.3.1 REFLOW SOLDERING

Reflow soldering techniques are suitable for all SO packages.

Reflow soldering requires solder paste (a suspension of fine solder particles, flux and binding agent) to be applied to the printed-circuit board by screen printing, stencilling or pressure-syringe dispensing before package placement.

Several techniques exist for reflowing; for example, thermal conduction by heated belt. Dwell times vary between 50 and 300 seconds depending on heating method. Typical reflow temperatures range from 215 to 250 °C.

Preheating is necessary to dry the paste and evaporate the binding agent. Preheating duration: 45 minutes at 45 °C.

16.3.2 WAVE SOLDERING

Wave soldering techniques can be used for all SO packages if the following conditions are observed:

- A double-wave (a turbulent wave with high upward pressure followed by a smooth laminar wave) soldering technique should be used.
- The longitudinal axis of the package footprint must be parallel to the solder flow.
- The package footprint must incorporate solder thieves at the downstream end.

During placement and before soldering, the package must be fixed with a droplet of adhesive. The adhesive can be applied by screen printing, pin transfer or syringe dispensing. The package can be soldered after the adhesive is cured.

Maximum permissible solder temperature is 260 °C, and maximum duration of package immersion in solder is 10 seconds, if cooled to less than 150 °C within 6 seconds. Typical dwell time is 4 seconds at 250 °C.

A mildly-activated flux will eliminate the need for removal of corrosive residues in most applications.

16.3.3 REPAIRING SOLDERED JOINTS

Fix the component by first soldering two diagonally-opposite end leads. Use only a low voltage soldering iron (less than 24 V) applied to the flat part of the lead. Contact time must be limited to 10 seconds at up to 300 °C. When using a dedicated tool, all other leads can be soldered in one operation within 2 to 5 seconds between 270 and 320 °C.

Clock/calendar with Power Fail Detector

PCF8573

17 DEFINITIONS

| | |
|---|---|
| Data sheet status | |
| Objective specification | This data sheet contains target or goal specifications for product development. |
| Preliminary specification | This data sheet contains preliminary data; supplementary data may be published later. |
| Product specification | This data sheet contains final product specifications. |
| Limiting values | |
| Limiting values given are in accordance with the Absolute Maximum Rating System (IEC 134). Stress above one or more of the limiting values may cause permanent damage to the device. These are stress ratings only and operation of the device at these or at any other conditions above those given in the Characteristics sections of the specification is not implied. Exposure to limiting values for extended periods may affect device reliability. | |
| Application information | |
| Where application information is given, it is advisory and does not form part of the specification. | |

18 LIFE SUPPORT APPLICATIONS

These products are not designed for use in life support appliances, devices, or systems where malfunction of these products can reasonably be expected to result in personal injury. Philips customers using or selling these products for use in such applications do so at their own risk and agree to fully indemnify Philips for any damages resulting from such improper use or sale.

19 PURCHASE OF PHILIPS I²C COMPONENTS

Purchase of Philips I²C components conveys a license under the Philips' I²C patent to use the components in the I²C system provided the system conforms to the I²C specification defined by Philips. This specification can be ordered using the code 9398 393 40011.

Clock/calendar with Power Fail Detector

PCF8573

NOTES

Philips Semiconductors – a worldwide company

Argentina: see South America

Australia: 34 Waterloo Road, NORTH RYDE, NSW 2113,
Tel. +61 2 9805 4455, Fax. +61 2 9805 4466

Austria: Computerstr. 6, A-1101 WIEN, P.O. Box 213,
Tel. +43 1 60 101, Fax. +43 1 60 101 1210

Belarus: Hotel Minsk Business Center, Bld. 3, r. 1211, Volodarski Str. 6,
220050 MINSK, Tel. +375 172 200 733, Fax. +375 172 200 773

Belgium: see The Netherlands

Brazil: see South America

Bulgaria: Philips Bulgaria Ltd., Energoproject, 15th floor,
51 James Bourchier Blvd., 1407 SOFIA,
Tel. +359 2 689 211, Fax. +359 2 689 102

Canada: PHILIPS SEMICONDUCTORS/COMPONENTS,
Tel. +1 800 234 7381

China/Hong Kong: 501 Hong Kong Industrial Technology Centre,
72 Tat Chee Avenue, Kowloon Tong, HONG KONG,
Tel. +852 2319 7888, Fax. +852 2319 7700

Colombia: see South America

Czech Republic: see Austria

Denmark: Prags Boulevard 80, PB 1919, DK-2300 COPENHAGEN S,
Tel. +45 32 88 2636, Fax. +45 31 57 1949

Finland: Sinikalliontie 3, FIN-02630 ESPOO,
Tel. +358 9 615800, Fax. +358 9 61580/xxx

France: 4 Rue du Port-aux-Vins, BP317, 92156 SURESNES Cedex,
Tel. +33 1 40 99 6161, Fax. +33 1 40 99 6427

Germany: Hammerbrookstraße 69, D-20097 HAMBURG,
Tel. +49 40 23 53 60, Fax. +49 40 23 536 300

Greece: No. 15, 25th March Street, GR 17778 TAVROS/ATHENS,
Tel. +30 1 4894 339/239, Fax. +30 1 4814 240

Hungary: see Austria

India: Philips INDIA Ltd, Shivsagar Estate, A Block, Dr. Annie Besant Rd.
Worli, MUMBAI 400 018, Tel. +91 22 4938 541, Fax. +91 22 4938 722

Indonesia: see Singapore

Ireland: Newstead, Clonskeagh, DUBLIN 14,
Tel. +353 1 7640 000, Fax. +353 1 7640 200

Israel: RAPAC Electronics, 7 Kehilat Saloniki St, TEL AVIV 61180,
Tel. +972 3 645 0444, Fax. +972 3 649 1007

Italy: PHILIPS SEMICONDUCTORS, Piazza IV Novembre 3,
20124 MILANO, Tel. +39 2 6752 2531, Fax. +39 2 6752 2557

Japan: Philips Bldg 13-37, Kohnan 2-chome, Minato-ku, TOKYO 108,
Tel. +81 3 3740 5130, Fax. +81 3 3740 5077

Korea: Philips House, 260-199 Itaewon-dong, Yongsan-ku, SEOUL,
Tel. +82 2 709 1412, Fax. +82 2 709 1415

Malaysia: No. 76 Jalan Universiti, 46200 PETALING JAYA, SELANGOR,
Tel. +60 3 750 5214, Fax. +60 3 757 4880

Mexico: 5900 Gateway East, Suite 200, EL PASO, TEXAS 79905,
Tel. +9-5 800 234 7381

Middle East: see Italy

Netherlands: Postbus 90050, 5600 PB EINDHOVEN, Bldg. VB,
Tel. +31 40 27 82785, Fax. +31 40 27 88399

New Zealand: 2 Wagener Place, C.P.O. Box 1041, AUCKLAND,
Tel. +64 9 849 4160, Fax. +64 9 849 7811

Norway: Box 1, Manglerud 0612, OSLO,
Tel. +47 22 74 8000, Fax. +47 22 74 8341

Philippines: Philips Semiconductors Philippines Inc.,
106 Valero St. Salcedo Village, P.O. Box 2108 MCC, MAKATI,
Metro MANILA, Tel. +63 2 816 6380, Fax. +63 2 817 3474

Poland: Ul. Lukiska 10, PL 04-123 WARSZAWA,
Tel. +48 22 612 2831, Fax. +48 22 612 2327

Portugal: see Spain

Romania: see Italy

Russia: Philips Russia, Ul. Usatcheva 35A, 119048 MOSCOW,
Tel. +7 095 755 6918, Fax. +7 095 755 6919

Singapore: Lorong 1, Toa Payoh, SINGAPORE 1231,
Tel. +65 350 2538, Fax. +65 251 6500

Slovakia: see Austria

Slovenia: see Italy

South Africa: S.A. PHILIPS Pty Ltd., 195-215 Main Road Martindale,
2092 JOHANNESBURG, P.O. Box 7430 Johannesburg 2000,
Tel. +27 11 470 5911, Fax. +27 11 470 5494

South America: Rua do Rocio 220, 5th floor, Suite 51,
04552-903 São Paulo, SÃO PAULO - SP, Brazil,
Tel. +55 11 821 2333, Fax. +55 11 829 1849

Spain: Balmes 22, 08007 BARCELONA,
Tel. +34 3 301 6312, Fax. +34 3 301 4107

Sweden: Kottbygatan 7, Akalla, S-16485 STOCKHOLM,
Tel. +46 8 632 2000, Fax. +46 8 632 2745

Switzerland: Allmendstrasse 140, CH-8027 ZÜRICH,
Tel. +41 1 488 2686, Fax. +41 1 481 7730

Taiwan: Philips Semiconductors, 6F, No. 96, Chien Kuo N. Rd., Sec. 1,
TAIPEI, Taiwan Tel. +886 2 2134 2870, Fax. +886 2 2134 2874

Thailand: PHILIPS ELECTRONICS (THAILAND) Ltd.,
209/2 Sanpavuth-Bangna Road Prakanong, BANGKOK 10260,
Tel. +66 2 745 4090, Fax. +66 2 398 0793

Turkey: Talatpasa Cad. No. 5, 80640 GÜLTEPE/ISTANBUL,
Tel. +90 212 279 2770, Fax. +90 212 282 6707

Ukraine: PHILIPS UKRAINE, 4 Patrice Lumumba str., Building B, Floor 7,
252042 KIEV, Tel. +380 44 264 2776, Fax. +380 44 268 0461

United Kingdom: Philips Semiconductors Ltd., 276 Bath Road, Hayes,
MIDDLESEX UB3 5BX, Tel. +44 181 730 5000, Fax. +44 181 754 8421

United States: 811 East Arques Avenue, SUNNYVALE, CA 94088-3409,
Tel. +1 800 234 7381

Uruguay: see South America

Vietnam: see Singapore

Yugoslavia: PHILIPS, Trg N. Pasica 5/v, 11000 BEOGRAD,
Tel. +381 11 625 344, Fax. +381 11 635 777

For all other countries apply to: Philips Semiconductors, Marketing & Sales Communications,
Building BE-p, P.O. Box 218, 5600 MD EINDHOVEN, The Netherlands, Fax. +31 40 27 24825

Internet: <http://www.semiconductors.philips.com>

© Philips Electronics N.V. 1997

SCA53

All rights are reserved. Reproduction in whole or in part is prohibited without the prior written consent of the copyright owner.

The information presented in this document does not form part of any quotation or contract, is believed to be accurate and reliable and may be changed without notice. No liability will be accepted by the publisher for any consequence of its use. Publication thereof does not convey nor imply any license under patent- or other industrial or intellectual property rights.

Printed in The Netherlands

417067/1200/03/pp24

Date of release: 1997 Mar 28

Document order number: 9397 750 01674

Let's make things better.

**Philips
Semiconductors**



PHILIPS