

FEATURES

- Integrated X- and Y-axis gyro on a single chip
- Factory trimmed full scale range of $\pm 500^\circ/\text{sec}$
- Integrated low-pass filters
- High vibration rejection over a wide frequency range
- High cross-axis isolation by design
- 3V single supply operation
- 5000 g shock tolerance
- RoHS compliant (completely lead free)
- 6 x 6 x 1.5mm QFN package

APPLICATIONS

- Inertial measurement units (IMUs)
- Handheld GPS navigation devices
- Radio controlled helicopters
- Toys and game consoles
- Robotic and power tools
- Antenna positioning
- Remote control

GENERAL DESCRIPTION

The IDG-300 is an integrated dual-axis angular rate sensor (gyroscope). It uses InvenSense's proprietary and patented MEMS technology with vertically driven, vibrating masses to make a functionally complete, low-cost, dual-axis angular rate sensor. All required electronics are integrated onto a single chip with the sensor.

The IDG-300 gyro uses two sensor elements with novel vibrating dual-mass bulk silicon configurations that sense the rate of rotation about the X- and Y-axis (in-plane sensing). This results in a unique, integrated dual-axis gyro with guaranteed-by-design vibration rejection and high cross-axis isolation. It is specifically designed for demanding consumer applications requiring low cost, small size and high performance.

The IDG-300 gyro includes integrated electronics necessary for application-ready functionality. It incorporates X- and Y-axis low-pass filters and an EEPROM for on-chip factory calibration of the sensor. Factory trimmed scale factors eliminate the need for external active components and end-user calibration. This product is lead-free and Green Compliant.

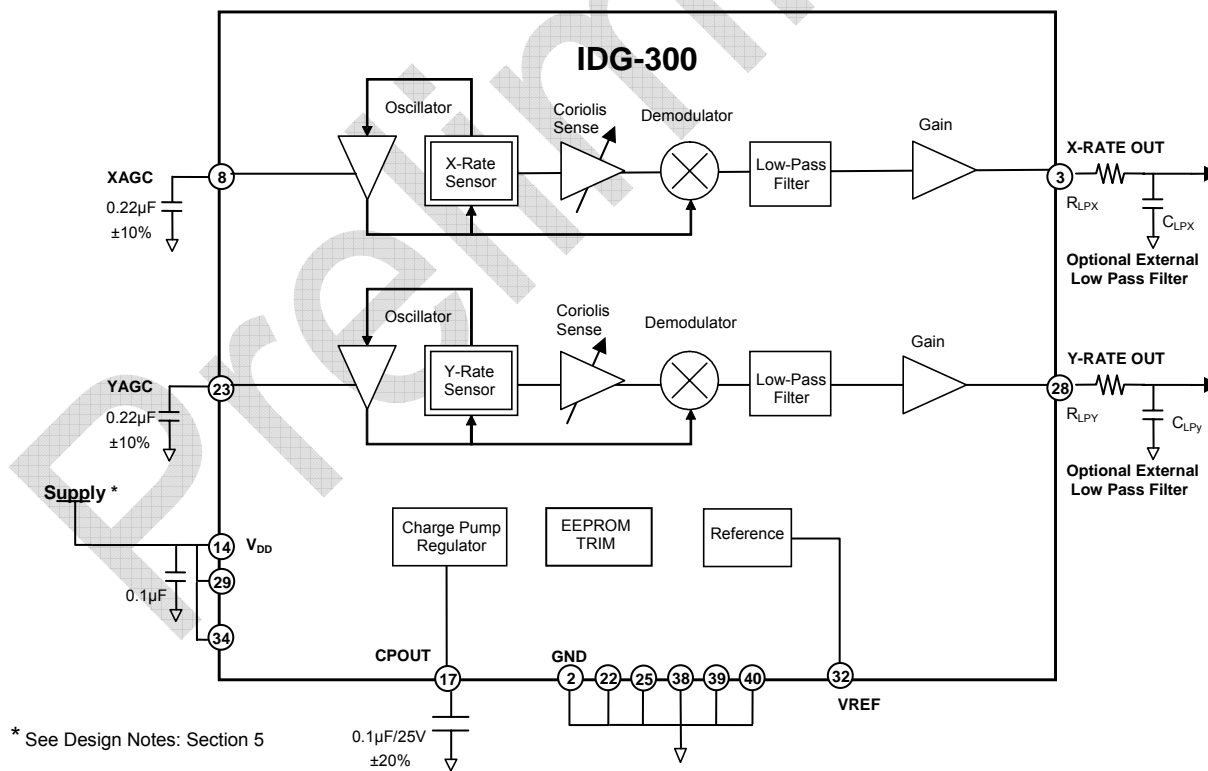

Reference Application Diagram



SPECIFICATIONS

All parameters specified are @ VDD=3.0 V and Ta=25°C.
 External LPF @ 2kHz. All specifications apply to both axes.

Parameters	Conditions	Min	Typical	Max	Unit
SENSITIVITY Full-Scale Range Sensitivity Initial Calibration Tolerance Over Specified Temperature Nonlinearity Cross-axis Sensitivity	Best Fit Straight Line	-5	±500 2.0 ±10 <1 ±2	+5	°/s mV/°/s % % % of FS %
ZERO-RATE OUTPUT Static Output (Bias) Initial Calibration Tolerance Over Specified Temperature		-300 -300	1.5	+300 +300	V mV mV
FREQUENCY RESPONSE High Frequency Cutoff LPF Phase Delay	Internal LPF -90° 10Hz		140 -4.5		Hz °
MECHANICAL FREQUENCIES Resonant Frequency Resonant Frequency Frequency Separation	X-Axis Gyroscope Y-Axis Gyroscope X and Y Gyroscopes	10 13	12 15 3	14 17	kHz kHz kHz
NOISE PERFORMANCE Rate Noise Density			0.014		°/s/√Hz
OUTPUT DRIVE CAPABILITY Output Voltage Swing Capacitive Load Drive Output Impedance	Load = 100kΩ to V _{dd} /2	0.05	100 100	V _{dd} -0.05	V pF Ω
REFERENCE Voltage Value Load Drive Capacitive Load Drive Power Supply Rejection Over Specified Temperature	Load directly connected to VREF VDD= 3.0V to 3.3V		1.23 1 100 1 ±5		V mA pF mV/V mV
POWER TIMING Zero-rate Output	Settling to ±3°/sec		200		ms
POWER SUPPLY Operating Voltage Range Quiescent Supply Current Over Specified Temperature		3.0	±2	3.3 9.5	V mA mA
TEMPERATURE RANGE Specified Temperature Range Extended Temperature Range	Performance parameters are not applicable beyond Specified Temperature Range		0 to +70 -20 to +85		°C °C

RECOMMENDED OPERATING CONDITIONS

Parameter	Min	Typical	Max	Unit
Power Supply Voltage (VDD)	3.0		3.3	V
Power Supply Voltage (VDD) Rise Time (10% - 90%)			20	ms

ABSOLUTE MAXIMUM RATINGS

Stress above those listed as "Absolute Maximum Ratings" may cause permanent damage to the device. This is a stress rating only and functional operation of the device under these conditions is not implied. Exposure to absolute maximum rating conditions for extended periods may affect device reliability.

Parameter	Rating
Supply Voltage	-0.3V to +6.0V
Acceleration (Any Axis, unpowered)	5000g for 0.3ms
Operating Temperature Range	-40 to +105°C
Storage Temperature Range	-40 to +125°C

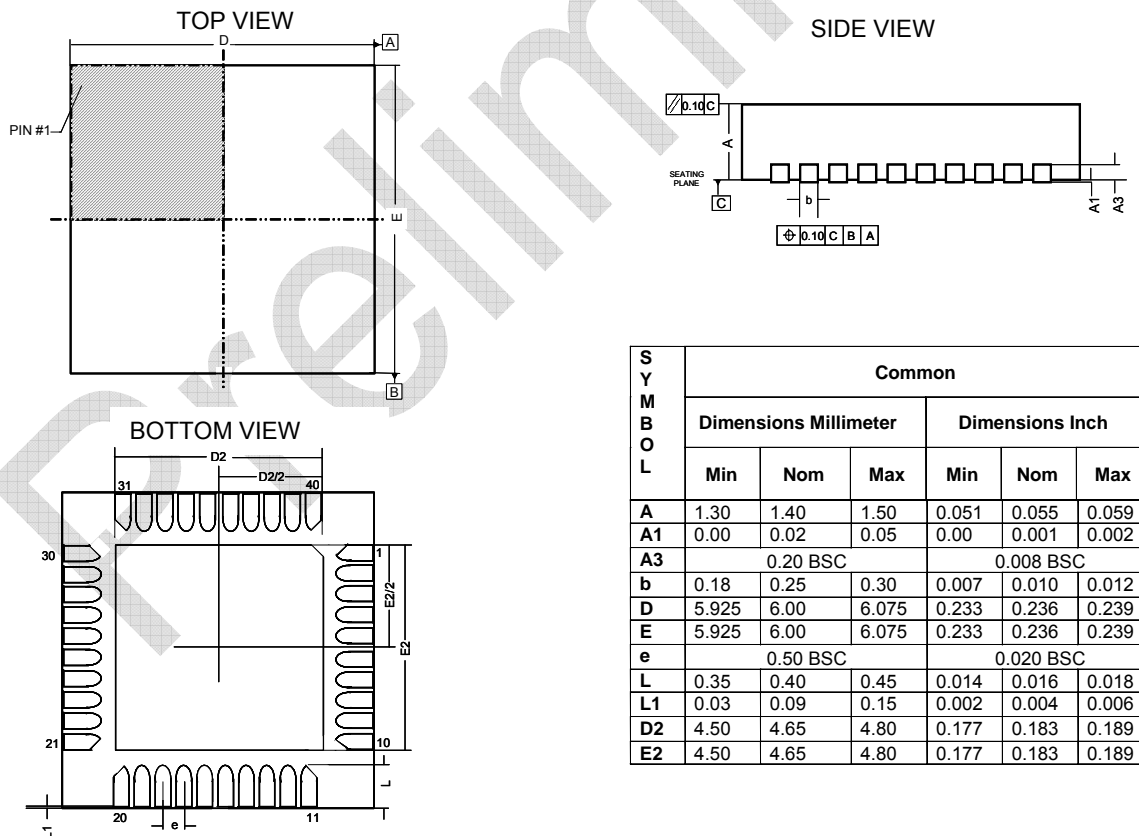
PACKAGE DIMENSIONS (all dimensions in mm)

PIN DESCRIPTION

Number	Pin	Description
2, 22, 25, 38, 39, 40	GND	Ground
14, 29, 34	VDD	Positive supply voltage: +3.0V to +3.3V
3	X-Rate Out	X-Rate Out
8	XAGC	Amplitude control filter (See Design Notes: Section 2)
17	CPOUT	Charge pump capacitor
23	YAGC	Amplitude control filter (See Design Notes: Section 2)
28	Y-Rate Out	Y-Rate Out
32	VREF	1.23V precision reference output
1, 9, 10, 11, 12, 13, 15, 16, 18, 19, 20, 21, 30, 31, 33, 35, 36, 37	RESV	Reserved. Do not connect. Used for factory trimming
4, 5, 6, 7, 24, 26, 27	NC	Not internally connected; may be used for PCB routing

PIN CONNECTION (TOP VIEW)

RATE SENSITIVE AXIS

This is a dual-axis rate sensing device. It produces a positive output voltage for rotation about the X- or Y-axis, as shown in the figure below.

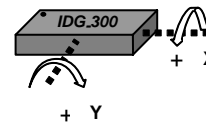
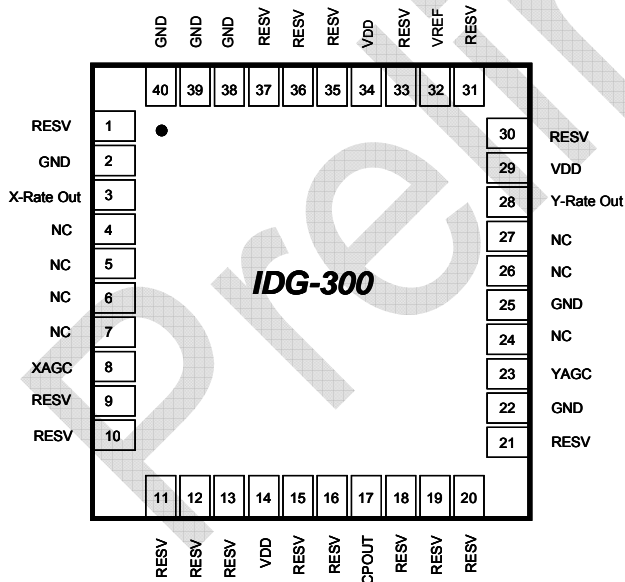

40 pin QFN Package
6 x 6 x 1.5mm

DESIGN NOTES
1. Overview

The IDG-300 gyro is a dual-axis gyroscope consisting of two independent vibratory MEMS gyroscopes. One detects rotation about the X-axis; the other detects rotation about the Y-axis. Each structure is fabricated using InvenSense's proprietary bulk silicon technology. The structures are covered and hermetically sealed at the wafer-level. The cover shields the gyro from EMI.

The gyroscope's proof-masses are electrostatically oscillated at resonance. An internal automatic gain control circuit precisely sets the oscillation of the proof masses. When the sensor is rotated about the X- or Y-axis, the Coriolis effect causes a vibration that can be detected by a capacitive pickoff. The resulting signal is amplified, demodulated, and filtered to produce an analog voltage that is proportional to the angular rate.

2. Amplitude Control

The scale factor of the gyroscope depends on the amplitude of the mechanical motion and the trim setting of the internal programmable gain stages. The oscillation circuit precisely controls the amplitude to maintain constant sensitivity over the temperature range. The capacitors (0.22 μ F, \pm 10%) connected to Pin 8 (XAGC) and Pin 23 (YAGC) are compensation capacitors for the amplitude control loops.

3. External Low-Pass Filter

An external low-pass filter is recommended to attenuate high-frequency noise. The cutoff frequency should be less than 2 kHz to attenuate tones above 10 kHz generated by the vibrating proof-masses. Recommended RC values for the 2 kHz filter are RLPX/RLPY and CLPX/CLPY are 750 Ω and 0.1 μ F respectively. The sensor bandwidth is limited to 140 Hz by the internal low-pass filter. Applications that require lower bandwidth should choose an external filter with a cutoff frequency less than 140Hz.

4. Scale Factor

The IDG-300 Rate-Out is not ratiometric to the supply voltage. The scale factor is calibrated at the factory and is nominally independent of supply voltage.

5. Power Supply Filtering

NOTE: Power supply Voltage (VDD) rise time (10% - 90%) must be less than 20 ms, at VDD (Pins 14 & 19), for proper device operation.

The IDG-300 gyro should be isolated from system power supply noise by a combination of an RC filter that attenuates high frequency noise and a Low Drop Out power supply regulator (LDO) that attenuates low frequency noise. The figure below shows a typical configuration.

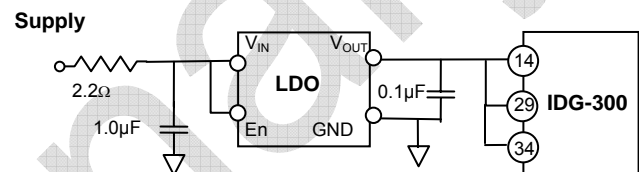

The low-pass RC filter should be chosen such that it provides significant attenuation of system noise at high frequencies. The LDO should be a low noise regulator (<100 μ V/rtHz) that exhibits good noise rejection at low frequencies.

6. VREF

VREF is a temperature independent voltage reference that can be used as a reference for an ADC. There is offset between the zero rate output and VREF.

7. High Impedance Nodes

XAGC (pin 8) and YAGC (pin 23) pins are high impedance (>1 Mohm) nodes. Any coating, glue or epoxy on these pins, or capacitors connected to these pins, will affect part performance and should be avoided.

Proper cleaning of PCB solder pads prior to SMT is recommended. PCB surface contaminants at XAGC (Pin 8), YAGC (Pin 23) or YHP2 (Pin 21) device interface may affect part performance.

8. Bias Drift

The gyroscope bias, which is the output when the angular velocity is zero, will drift over time due to factors such as temperature and stress. Such drift is present to some degree in all gyroscope systems, and must be addressed in the application.

The method for tracking bias depends on the design of the system itself. If the system has moments in which the angular velocity is known to be zero, the gyroscope bias can be measured at that time, and used when the system is moving. For example, in an automotive navigation system in which the wheel velocities are known, the gyroscope bias can be measured when the wheel velocities are zero. For a handheld pointing device, the bias can be measured when the device is not being held.

If other sensors are present in the system, these sensors can be used to track the gyroscope biases. Accelerometers can be used to measure tilt, and provide enough of a signal to calibrate gyroscope biases over long periods of time. In navigation systems, GPS signals can be used to calibrate gyroscope biases. Other systems may use infrared, magnetic, or vision based sensing to calibrate the gyroscope bias.

Preliminary

Preliminary

This information furnished by InvenSense is believed to be accurate and reliable. However, no responsibility is assumed by InvenSense for its use, or for any infringements or patents or other rights of third parties that may result from its use. Specifications are subject to change without notice. Certain intellectual property owned by InvenSense and described in this document is patent protected. No license is granted by implication or otherwise under any patent or patent rights of InvenSense. This publication supersedes and replaces all information previously supplied. Trademarks that are registered trademarks are the property of their respective companies. InvenSense sensors should not be used or sold in the development, storing, production and utilization of any conventional or mass-destructive weapons or any other weapons or life threatening applications, as well as in any other life critical applications such as medical equipment, transportation, aerospace and nuclear instruments, undersea equipment, power plant equipment, disaster prevention and crime prevention equipment.

©2007 InvenSense, Inc. All rights reserved.

